

# Adjustable Kitset Gate

Installation Guide

Products: Alpha, Eden, Nova, Belle & Bode



*A step-by-step guide to installing your fence*

# Introduction

Thank you for choosing Fentec Aluminium range. This product will provide you with many years of trouble free protection if installed in accordance with the directions outlined in this document.

The recommendations detailed in this guide are formulated along the lines of good building practice. They are not intended to be an exhaustive statement of all the relevant data.

If you have any questions, please contact our Technical Team on 0800 002 725. We are always happy to help in any way we can.

## Before you start, read this

This guide provides step-by-step instructions for assembling Fentec's Alpha, Eden, Nova, Belle or Bode Adjustabel Kitset Gates, ensuring a quick and simple set up process, including guidance on resizing the gate

For any questions, or if further assistance is required, please contact the Fentec Technical Team on 0800 002 725 or email [admin@fentec.co.nz](mailto:admin@fentec.co.nz).

## Tool List

Make sure you choose the right tools before you start your fence.

### Tools

- Drill
- Hex socket
- Tape measure
- Square
- Rubber mallet
- Clamps

### Optional

- Hacksaw/powerd metal cutting saw

### Safety Gear (minimum required)

- Safety boots
- Gloves
- Helmet
- Eye protection
- Hearing protection
- Sun protection

It is recommended that the reader pays particular attention to those items identified as **Important** in this manual to ensure satisfactory long-term performance.

# Component List

Take care when opening and unloading the package. Ensure all components are accounted for and check that nothing is damaged.

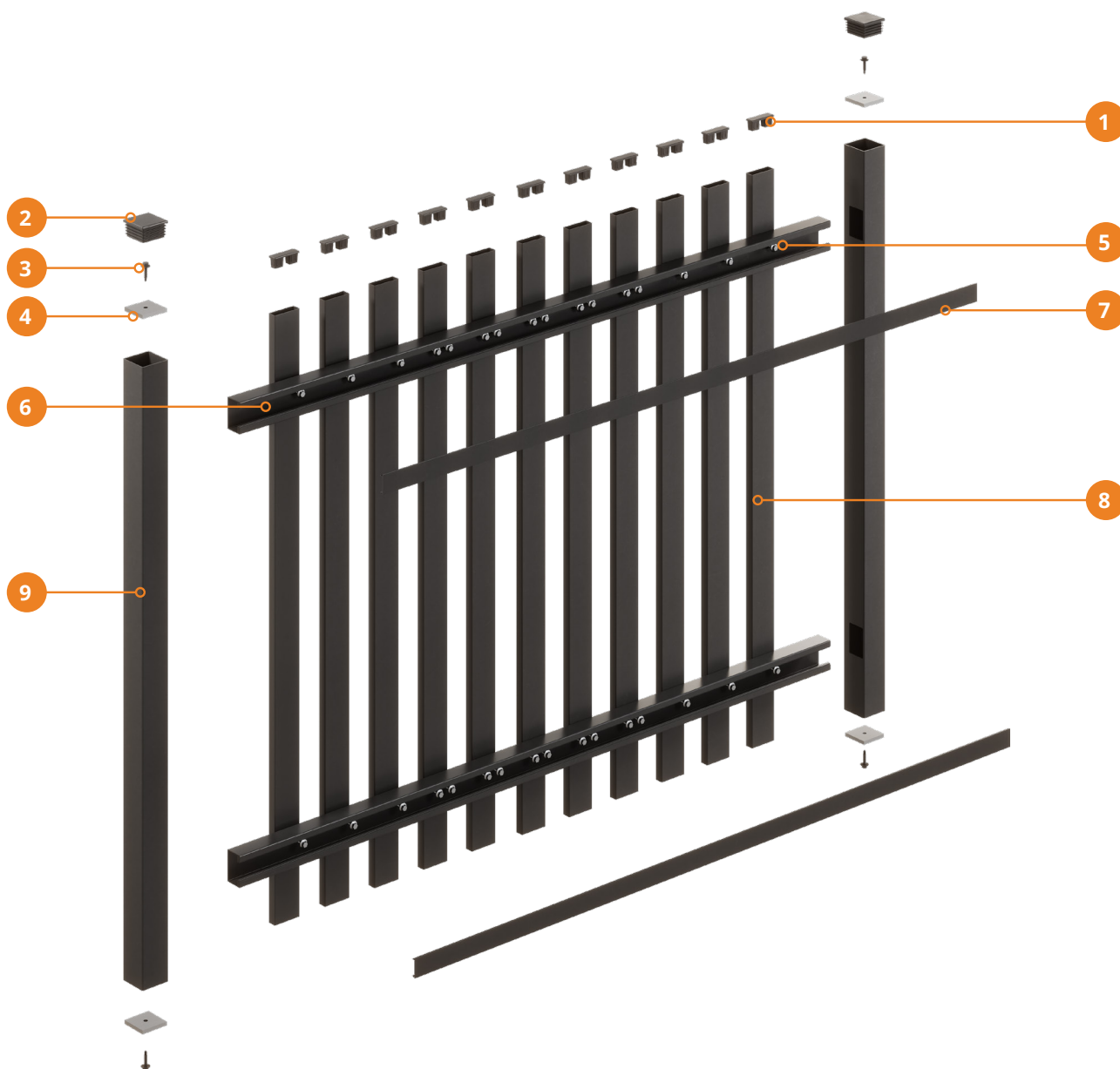

A complete kitset gate consists of:

1. Picket Caps



2. Stile Caps



3. Tek Screws  
12gx25mm



4. Retaining Clips

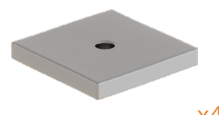

5. Tek Screws\*  
10gx16mm



6. Rails



7. Rail Cover

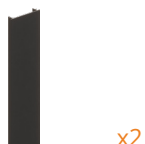

8. Pickets



9. Stiles



\*The centre 5 pickets are held on by two screws per picket to stabilise the gate.

The outer 3 pickets on both sides use only one screw per picket to prevent visible holes if the gate requires

## Step 1 > Measuring the gate

Kitset gates come in two standard widths, dependent on the style. Alpha, Bode and Nova are 1250mm wide. Eden and Belle are 1180mm wide.

The Kitset Gates are packaged partially assembled to make adjustments to the width easier.

Picket measurements are taken from the centres of the pickets, with each centre spaced 100mm apart.

This gives a variation in the gaps between the pickets for the Bode and Nova designs.

Measure the distance between the posts where the gate will be hung. From that measurement, allow an additional 20mm on either side for standard hinges and latches.

If the gate width is correct for your space go to [step 4 on page 6](#).

When measuring the gate for resizing, keep in mind, the rail should go all the way into the stile. The retaining clip is designed to be screwed directly into the centre of the stile to hold the rail in place.

Ensure the rail has the following allowances when measuring for resizing:

Alpha, Bode and Nova - up to 48mm  
(*stile width 50mm minus 2mm wall thickness*)

Eden and Belle - up to 72mm  
(*stile width 75mm minus 3mm wall thickness*)

100mm between picket centres  
Alpha, Bode and Nova - 1250mm  
Eden and Belle - 1180mm

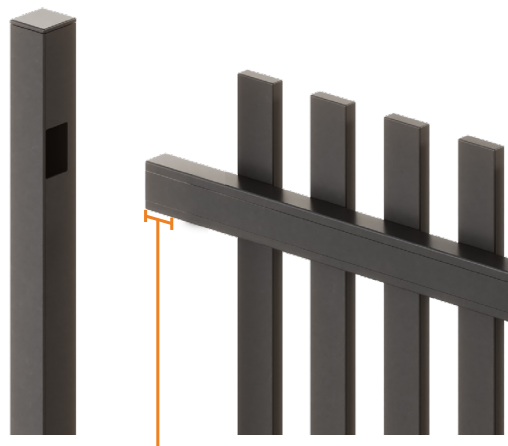
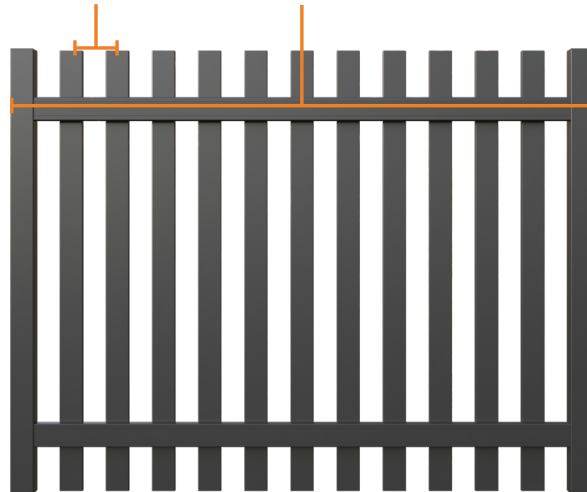

Allow length on rail to go into stile.

Alpha, Bode and Nova - up to 48mm  
Eden and Belle - up to 72mm

## Step 2 > Disassembling the gate

If the gate width is correct for your space go to [Step 4 on page 06](#).

1. Begin by removing either one of the stiles. Depending on the width required, both stiles may need removed to keep even gaps on both ends of the gate.
2. To remove the stile, first take off the stile cap and extract the retaining clip by removing the tek screw holding it in place. The retaining clip for the bottom rail is removed from the bottom of picket.
3. Once the stile has been removed, slide off the rail covers.
4. The three outer pickets on each end of the gate are attached with a single screw to make removal easier.
5. Mark the required length of the gate. Unscrew the tek screws and remove the necessary pickets to get the gate to the required size.

Ensure that enough rail length is allowed to reinstall the stile after cutting to size.



## Step 3 > Cutting the gate to size

1. Mark the required length of the gate.

Ensure the rail has the following allowances for going into the stile when measuring for resizing:

Alpha, Bode and Nova - up to 48mm (stile width 50mm minus 2mm wall thickness)

Eden and Belle - up to 72mm (stile width 75mm minus 3mm wall thickness)

2. Cut the rail at the marked length.
3. Once cut, slide the stile back onto the rail and brace or clamp into place.

Do not screw the stile into place at this stage, the stile will need to be removed again in order to slide the rail cover in.



Allow length on rail to go into stile  
Alpha, Bode and Nova - up to 48mm  
Eden and Belle - up to 72mm



## Step 4 > Reattaching pickets

1. Measure the empty space between the last picket and the stile. All pickets are spaced at 100mm between the centres of the pickets.
2. Arrange the necessary amount of pickets on a flat surface.
3. Place the partially assembled gate on top of the pickets and adjust the gaps between the pickets to ensure uniform spacing. A spacer cut to the width of the spaces can make this process easier.
4. Secure the pickets into position on the gate using a clamp.
5. Using the provided 10gx16mm tek screws, fasten 2x tek screws per picket into place from inside the channel. Ensure the gaps remain aligned between attaching each picket.
6. Check the pickets are aligned and properly attached. There should be no movement from the pickets.

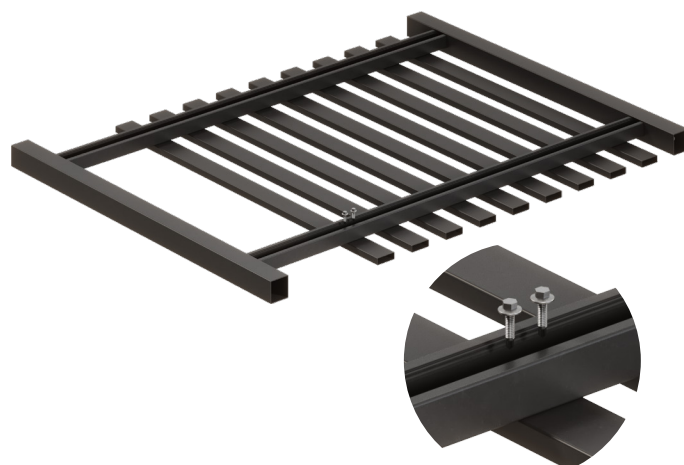
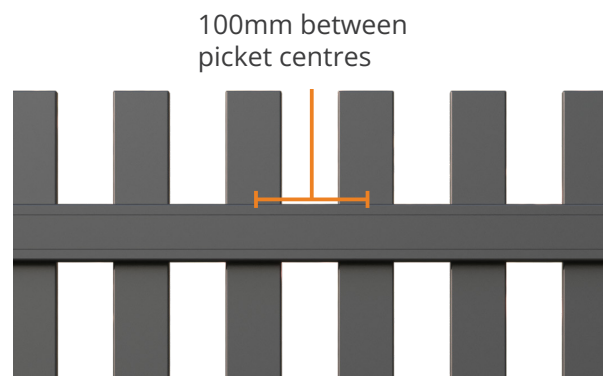

2x tek screws per picket

*Small 5 to 10mm differences are not typically noticeable.*

## Step 5 > Completing assembly

1. Once the pickets are fixed in place, slide the channel cover back onto the rail.
2. Slot the rails into the stile. The rail should go all the way into the stile.
3. Insert the retaining clip and screw that back into place with the 12gx25mm tek screw and then insert the post cap. A rubber mallet can be used to gently tap the cap into place.
4. Inspect the completed gate for stability and alignment and make any necessary adjustments.



## Step 6 > Installing the gate

Once the gate is completely assembled, it is ready to be installed.

1. Decide the best orientation for the gate. Determine whether it needs to be hinged on the left or right side, and if it needs to open inwards or outwards.
2. Install the hinges onto the gate. The recommended position for the hinges is set 100mm from the top and bottom of the stile. Position and attach the hinges to the stile using the provided screws.

Ensure the hinges are attached to the correct side of the stile.

3. Hang the gate. Set the gate in the gate way, making sure the top of the gate is level with the adjoining fence. It can make it easier to get a second person to assist with holding the gate.

Once the gate is in the correct position and is straight and level, screw the hinges to the post. Before fully fastening the hinges in place, open the gate to test the function. If no adjustments are required, fasten the screws completely and snap on the screw covers.

4. Install the latch. Refer to the manufacturer's instructions on how to install the latch, as this can vary depending on latch type.

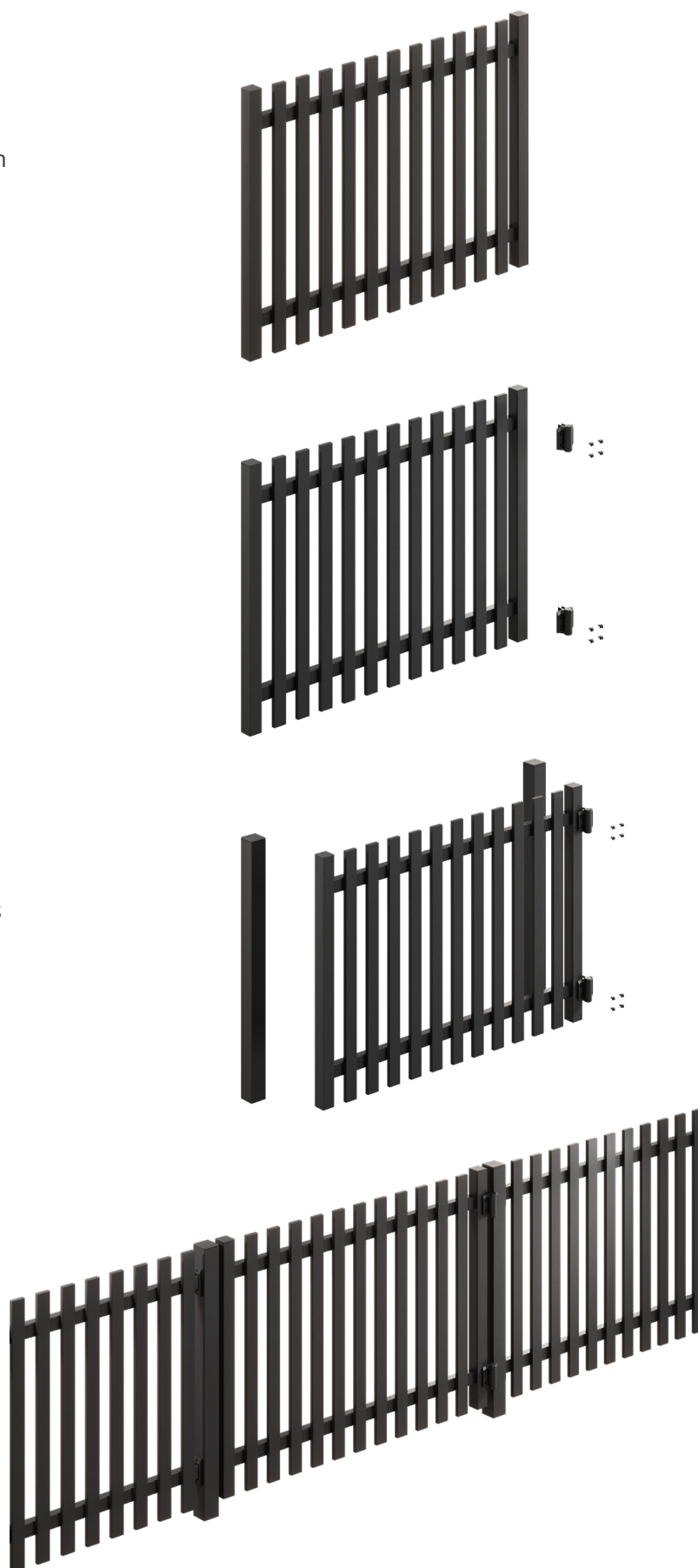

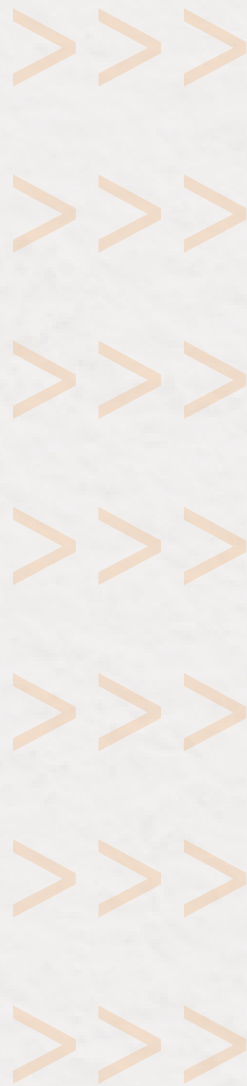

fentec.co.nz | 0800 002 725  
sales@fentec.co.nz

